

---

# Introduction to System Block Algebra

Course No: E02-013

Credit: 2 PDH

---

Jeffrey Cwalinski, P.E.

---

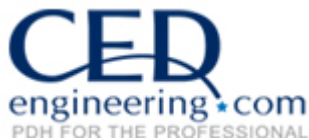

Continuing Education and Development, Inc.  
9 Greyridge Farm Court  
Stony Point, NY 10980

P: (877) 322-5800

F: (877) 322-4774

[info@cedengineering.com](mailto:info@cedengineering.com)

---

## Introduction to System Block Algebra

This course presents an introduction to system block algebra and manipulation of blocks for those who are unfamiliar with this subject. Topics covered in this course include the types of system block algebra symbols, input/output relationships of system blocks, as well as analysis and simplification of system block diagrams.

Systems are often described using block diagrams as visual aids. The blocks are used to implement mathematical operations, such as, addition and multiplication. They also can implement high level transfer functions. System block algebra can describe systems in the time domain,  $s$  domain, or  $z$  domain. After a system is described using blocks the diagram is usually simplified by combining blocks according to a set of established rules. Simplification may result in a diagram that is more understandable and easier to document, and a system that may be reduced to practice with fewer components and/or less software coding.

There are three components used in system block diagrams. First, to be discussed is the summing junction. It is a circle with one input, usually designated  $X$ , one output, usually designated  $Y$ , and one or more signals that are either added to or subtracted from the input, in this case  $A$  and  $B$ . Signal flow generally is left to right with the input to the left of the summing junction and the output to the right of the summing junction. Sometimes the output will be labeled with an arrow pointed away from the summing junction. The signals that are either added to or subtracted from the input are represented by arrows pointed at the summing junction. These signals will have a plus sign next to the arrow head if they are to be added, or a minus sign if they are to be subtracted. Traditionally, it is shown as below.

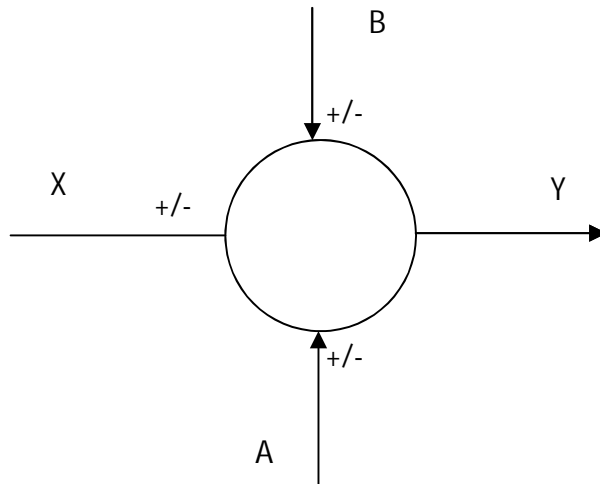

For this course, to eliminate any source of confusion, all signal paths will be labeled with directional arrow heads and all inputs will be labeled with a plus or minus sign, as shown below.

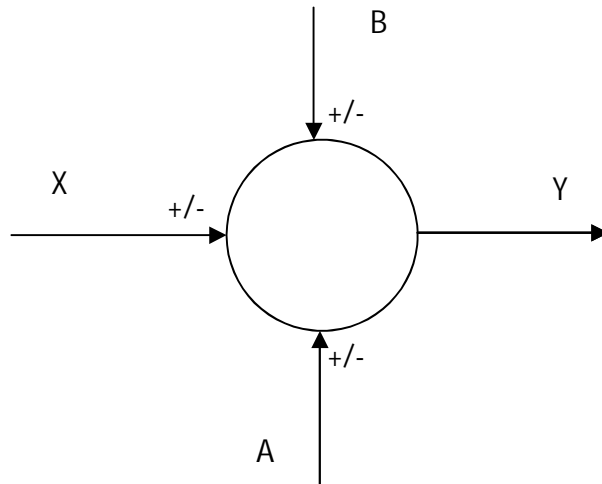

As an example:

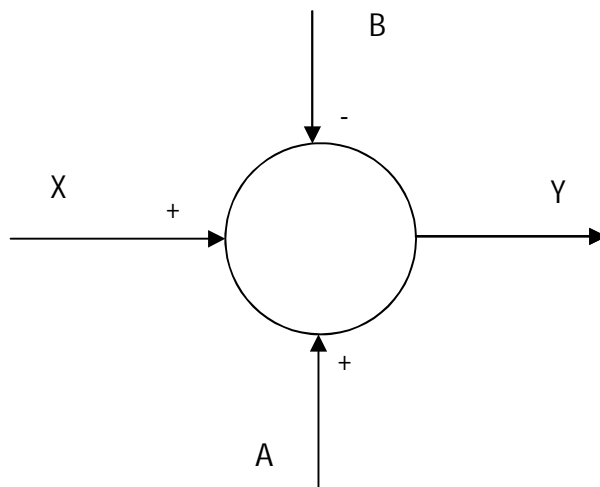

From the diagram above X is the input, Y is the output, A is added to the input, and B is subtracted from the input. The algebraic equation describing this is:

$$Y = X + A - B$$

The second symbol is the block, represented by a square. The block is generic, it can be used for multiplication, division, and to implement transfer functions. There is one input and one output. Sometimes the output is labeled with an arrow head pointing in the direction of signal flow. Signal flow may be left to right thru the block, or right to left thru the block. The direction of signal flow will always be clear from the context of the entire diagram. For this course arrow heads will always be used to indicate direction.

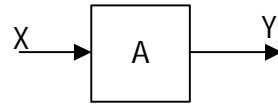

The block above represents multiplication by A. The algebraic equation is:

$$Y = AX$$

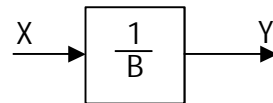

The block above represents division by B. The algebraic equation is:

$$Y = \frac{X}{B}$$

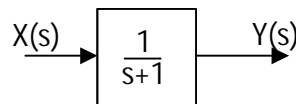

The block above represents implementation of a transfer function, H(s), in the s domain. The algebraic equation is:

$$Y(s) = \frac{X(s)}{s+1}, \text{ and } H(s) = \frac{Y(s)}{X(s)} = \frac{1}{s+1}$$

The third symbol used is the pick off point. It taps into a signal and directs it elsewhere. This allows one signal to have multiple destinations. It is represented by a dot on the signal line and a line connected from that dot to some destination. Sometimes there will be an arrow pointing away from the dot indicating the direction of signal flow.

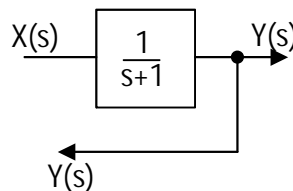

The diagram above indicates that signal Y(s) has two destinations.

As a final note on signal flow direction, arrow heads may be placed anywhere on the diagram to eliminate confusion.

There are a number of rules regarding the simplification of system block diagrams, they are listed below.

1. Blocks cascaded in series can be combined in to a single block by multiplying the contents of each block. A diagram is shown below:

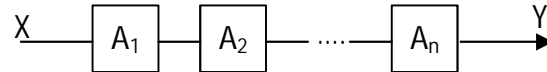

It can be replaced with:

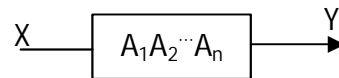

This is a single block that contains the product of the terms  $A_1$  thru  $A_n$ . The algebraic equation is:

$$Y=(A_1A_2\cdots A_n)X$$

2. Blocks in parallel can be combined as shown below.

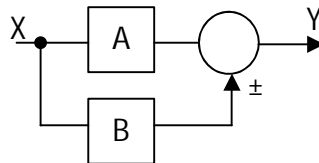

Can be replaced with the following:

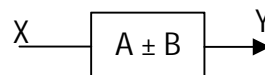

The algebraic equation is:

$$Y=(A\pm B)X$$

This can be easily derived using Rule 1 and the knowledge of the summing junction. The diagram is repeated below with points 1 and 2 labeled.

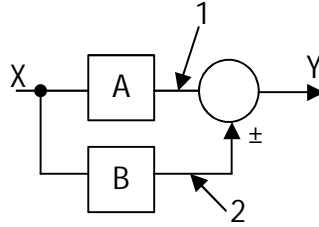

Using Rule 1 the value at point 1 is  $AX$ , and the value at point 2 is  $BX$ . At the output of the summing junction these values are either added or subtracted:

$$Y = AX \pm BX = (A \pm B)X$$

3. The diagram below represents the standard feedback diagram.

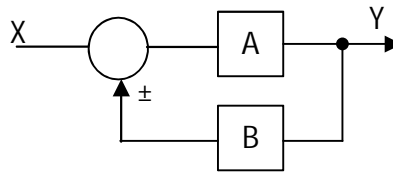

This can be replaced with:

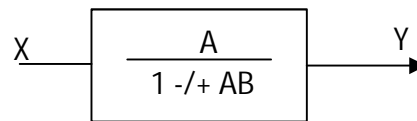

The algebraic equation is:

$$Y = \left( \frac{A}{1 \mp AB} \right) X$$

Note that when B is added at the summing junction the product AB is subtracted from 1, and when B is subtracted at the summing junction the product AB is added to 1.

This can be easily derived using Rule 1, the knowledge of the summing junction, and the knowledge of the pick off point. The diagram is repeated below with points 1 and 2 labeled and the plus/minus replaced with plus.

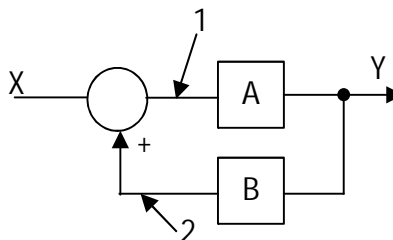

The value at point 2 is  $BY$ . The value at point 1 is  $X+BY$ . The value at  $Y$  is the value at point 1 multiplied by  $A$ ,  $Y = A(X+BY)$ . Using the following algebraic manipulation

$$Y = A(X+BY)$$

$$Y = AX+ABY$$

$$Y-ABY = AX$$

$$Y(1-AB) = AX$$

$$Y = \left(\frac{A}{1-AB}\right)X$$

The other case is left to the student as an exercise.

4. Multiple summing junctions can be combined in to one summing junction. The plus/minus signs have been left off for clarity.

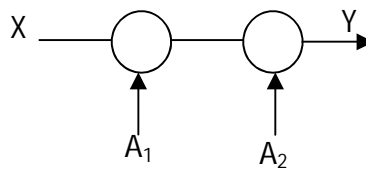

It can be replaced with:

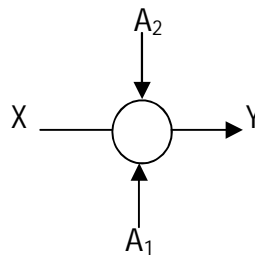

Assuming addition, the algebraic equation is:

$$Y=X+A_1+ A_2$$

5. A summing point can be moved behind a block:

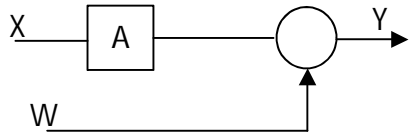

It can be replaced with:

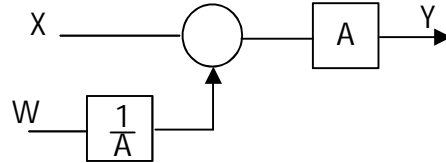

6. A summing point can be moved in front of a block:

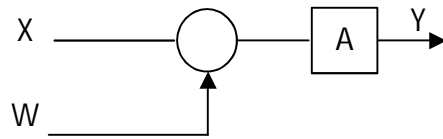

It can be replaced with:

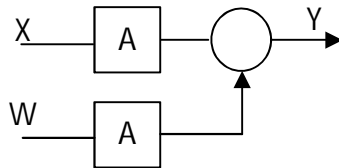

7. A pick off point can be moved behind a block:

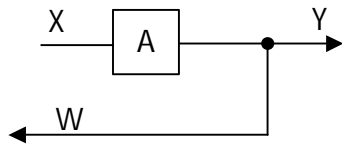

It can be replaced with:

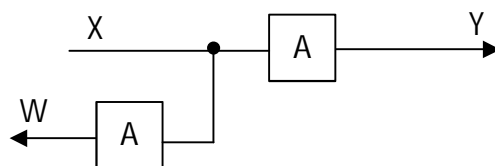



8. A pick off point can be moved in front of a block:

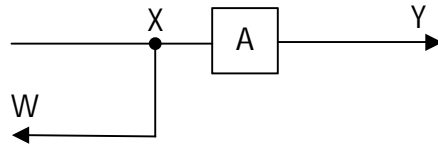

It can be replaced with:

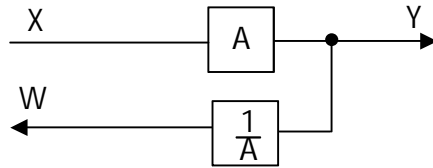

9. A straight line signal path passes the signal from one end to the other unchanged.



The equation that represents the above is  $Y = X$ . The straight line path can be changed to include a block with a value of 1, the unity operator.

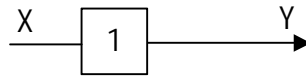

The equation remains unchanged,  $Y = X$ . This block has benefit in that it does eliminate uncertainty when simplifying diagrams. As an example, for the diagram below it may not be obvious what the value of the feedback loop is.

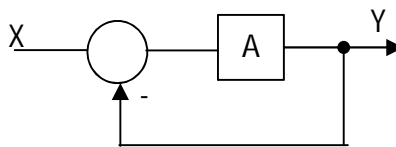

But when the unity operator is added to the line connected to the minus terminal of the summing junction it become apparent that it is the standard feedback diagram with  $B = 1$ .

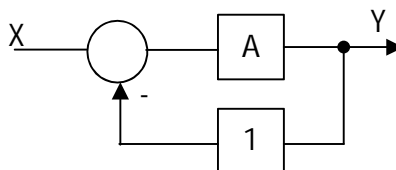

$$Y = \left( \frac{A}{1+A} \right) X$$

10. Minor modifications can be made to the diagram to simplify the diagram and possibly make the patterns described above more recognizable.

a. The diagram below:

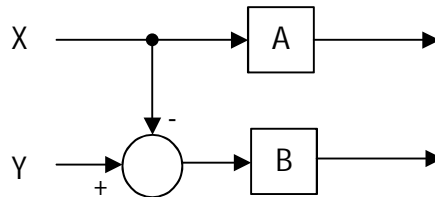

Can be changed to:

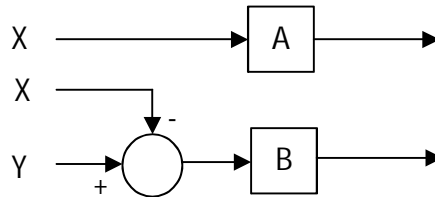

b. Signal paths connected to nodes may be split or combined provided that there are no components, blocks or summing junctions, between them. The two diagrams below are equivalent.

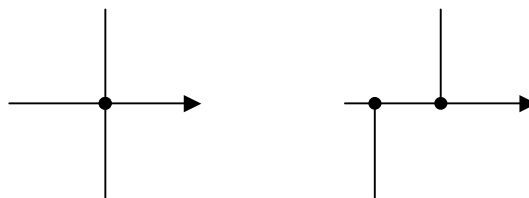

A block that is often encountered when working with discrete signals is the single sampling period delay operation and it will be represented by the word “Delay” in a block. A discrete output is represented by  $y[n]$  and a discrete input is represented by  $x[n]$ . The brackets around the argument indicate that the function is a discrete function of variable  $n$  which is called the sample index. Compare this to parenthesis which indicates a continuous function. As an example  $x(t)$  is a continuous function of variable  $t$ . Invoking the delay causes a previous value of the output or input to be used. And this is represented by subtracting 1 from the argument every time the delay is invoked.

As an example:

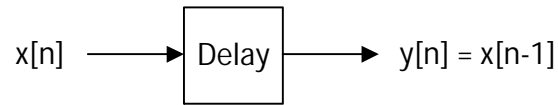

For the above block diagram the current value of the output,  $y[n]$  is equal to the input that occurred in the prior sample index,  $x[n-1]$ . Using another example:

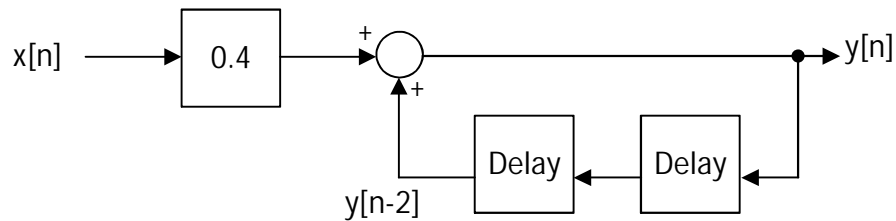

The delay can also be applied to the output,  $y[n]$ , and feed back to the input. The output equation can be solved for using the same techniques that were used for solving the standard feedback block, Rule 3. The output equation is:

$$y[n] = 0.4x[n] + y[n-2]$$

The current output,  $y[n]$ , is equal to 0.4 times the current input,  $x[n]$ , plus the output that was calculated two solutions ago,  $y[n-2]$ .

Block algebra is also used with the Z Transform. The Z Transform is the digital counterpart of the LaPlace Transform which is used in the analog world. The Z Transform is used where ever an analog signal is sampled with a constant sampling time which results in a sequence of numbers evenly spaced in time. Some applications include digital control systems, such as those that use a programmable logic controller (PLC) or an automated data acquisition program. The transform is also used in digital communications systems for digital signal processing, DSP, for short. It could be used to process video and audio in a DVD, or a telephone system where digital filtering could be used to reduce noise in the conversation.

Block algebra in the Z domain is identical to block algebra in the S domain with the exception that each "s" is are replaced with " $z^{-1}$ ". The "z" is sometimes called the sampled frequency variable. The power to which it is raised to represents a delay in terms of sampling intervals. The simplification techniques are the same.

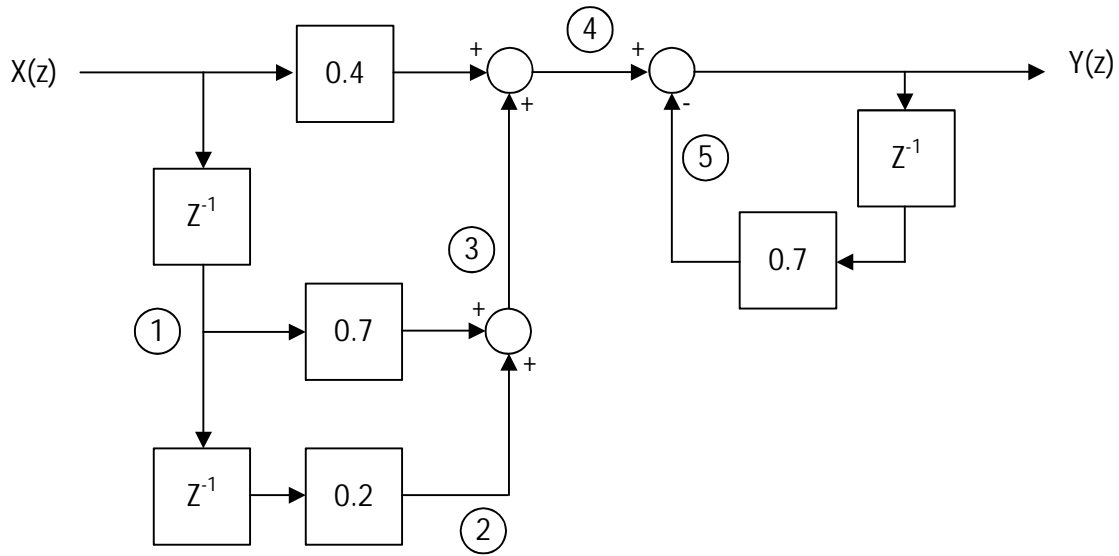

In the example above it is convenient to start with the left half. At point 1 the input is multiplied by  $z^{-1}$ , as such,  $X(z)z^{-1}$ . At point 2 the  $z^{-1}$  block and the 0.2 block are cascaded and can be replaced by one block,  $0.2z^{-1}$ . The multiplication yields an equation at point 2 of  $0.2X(z)z^{-2}$ . At point 3 the equation is  $0.7X(z)z^{-1} + 0.2X(z)z^{-2}$ . At point 4 the equation is  $0.4X(z) + 0.7X(z)z^{-1} + 0.2X(z)z^{-2}$ . In the right half, at point 5 the  $z^{-1}$  block and the 0.7 block are cascaded and can be replaced by one block,  $0.7z^{-1}$ . If this section is now redrawn, then it can be seen it is in the standard feedback form.

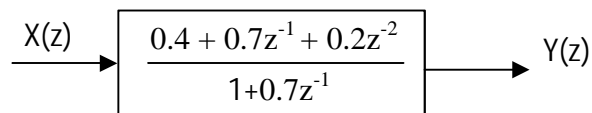
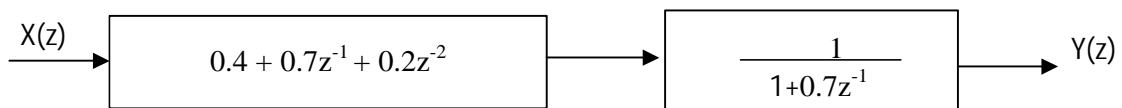
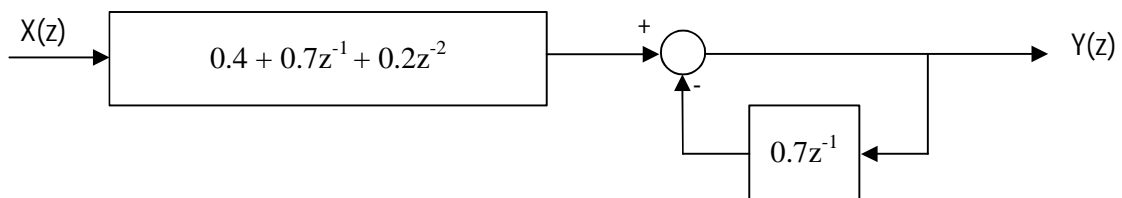

Another example is shown below.

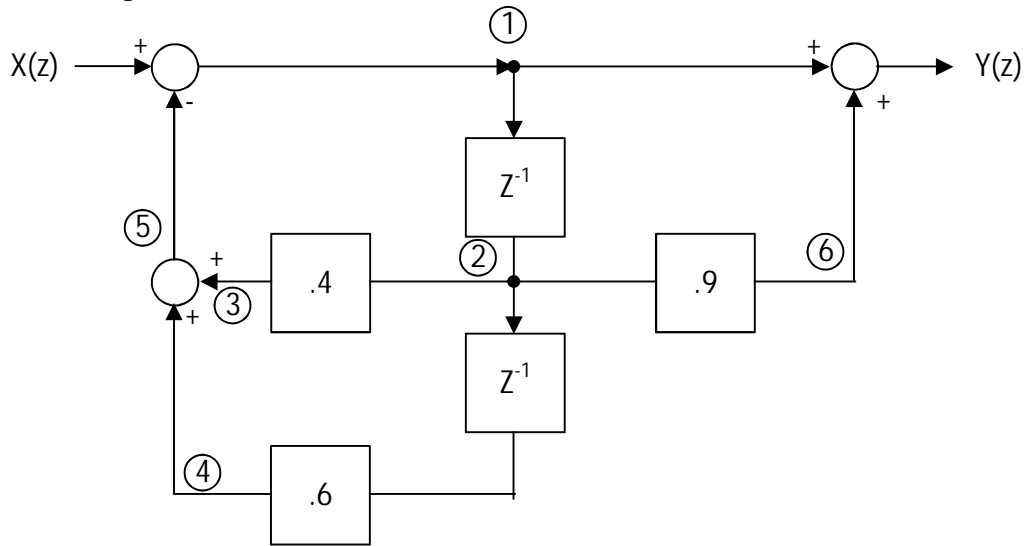

At point 1 define a variable,  $R(z)$ , which will be solved for in terms of  $X(z)$  by tracing it thru the signal path down and to the left as defined by points 1 thru 5.

At point 2  $R(z)$  is multiplied by  $Z^{-1}$ , which results in  $R(z) Z^{-1}$ . The  $Z^{-1}$  and 0.6 blocks are cascaded together and when multiplied by  $R(z) Z^{-1}$  result in  $0.6R(z) Z^{-2}$  at point 4. At point 3  $R(z) Z^{-1}$  is multiplied by 0.4, which results in  $0.4R(z) Z^{-1}$ . At point 5 they are summed together to yield  $0.6R(z) Z^{-2} + 0.4R(z) Z^{-1}$ . After going thru the summing junction the equation in terms of  $X(z)$ ,  $R(z) = X(z) - (0.6R(z) Z^{-2} + 0.4R(z) Z^{-1})$ . After some algebra,

$$R(z) = \frac{X(z)}{1 + 0.6Z^{-2} + 0.4Z^{-1}}$$

At point 6  $R(z) Z^{-1}$  is multiplied by 0.9 to yield:

$$\frac{0.9Z^{-1}}{1 + 0.6Z^{-2} + 0.4Z^{-1}} X(z)$$

The output  $Y(z)$  is the sum of the equations at points 1 and 6:

$$Y(z) = \frac{1+0.9Z^{-1}}{1+0.6Z^{-2}+0.4Z^{-1}} X(z).$$

Solving examples involves recognizing patterns that fall under the rules 1 thru 10 above and making the substitutions. Although for some diagrams it is easier to trace the input thru the diagram using the value of the output of one block or summing junction as the input to the next block or summing junction. Finally, there are times when a combination of the two techniques is required, and the algebra is tedious.